

CITY COUNCIL
COMMITTEE ON ZONING, LANDMARKS AND BUILDING STANDARDS
COUNCIL ORDER

RE: Approval of sign over 100 square feet in area or over 24 feet above grade

ORDERED, that the City Council hereby approves the following sign application submitted by:

Applicant*: Burlington Stores, Inc.

(* The Applicant is the owner of the real property or the business tenant of the real property. Do not list the sign contractor, sign erector, sign company or advertising entity in the above space.)

This Order approves the following sign in accordance with Municipal Code of Chicago Section 13-20-680:

Address of Sign: 5227 Broadway Chicago, IL 60640

Zoning District: B1-3

DOB Sign Permit Application #: 101043819

Sign Details:

1. On-premise OR Off-premise

2. Static sign OR Dynamic-image display sign

3. Number of sign faces 1

4. Projecting over the public way Yes (Yes or No) If yes, Public Way Use #: BACP1915299

5. Dimensions: Length 30 feet 9 inches Height 8 feet 3 inches

Total square feet in area: 254

6. Height above grade: 25 feet 3 inches **To top of sign or sign structure**

7. Elevation (side of building or lot where the sign will be erected): West

8. Name of Sign Contractor/Erector: Kdn Signs

To be legal, such sign shall comply with all provisions of Title 17 of the Chicago Municipal Code ("Zoning Ordinance") and all other provisions of the Municipal Code governing the permitting, construction and maintenance and removal of signs and sign structures. Failure of the applicant and the applicant's successors to comply shall be grounds for invalidation or revocation of the sign permit.

Alderman

48

Ward

Side Elevation

S2

Proposed Signage = 252 SF
Relevant Signage Code
 3 x linear frontage per elevation with frontage
 Side Elevation total allowable 597sqft

Sign Type
 Letters: LED Channel Letterset - Front-Lit,
 Cabinet: LED Channel Cabinet - Halo Lit,

Mounting
 Letters: Flush Mounted
 Cabinet: Standoff Mounted

- Color Palette**
- Face: White Acrylic
 - Burlington Trims & Returns: Black
 - Letters Vinyl: Trans vinyl to match PMS 207c
 - Tagline Vinyl: 3M 3630-222 Day/Night Black
 - Tagline Returns: White
 - WOW Cabinet Trims & Returns: Black
 - WOW Cabinet: Clear Acrylic
 - WOW Cabinet: White Lexan

Project No. 21635
Project Burlington Signage Package
Location 5227 N. Broadway Street
 Chicago, IL 60640
 Broadway Plaza
Orig. Draft 11.16.2022
Project Mgr. N/A
Designer IDV
Rev. Art MM
Rev. Date 11.22.2023
Page Rev. 015
Rev. Details Revised logo

This sign design is exclusive property of Identiti Resources, LTD., and is the result of the original and creative work of it's employees. This drawing is submitted to the customer for the sole purpose of purchase of the design or signage manufactured to this design, by Identiti Resources, LTD. Distribution to or use of this sign design by anyone outside of the customer's organization, without expressed, written authorization by Identiti Resources, LTD. is prohibited.

425 N Martingale Rd
 18th Floor
 Schaumburg, IL 60173
 O ce 847.301.0510
 identiti.net



RENDER IS AN ESTIMATION
ALL DIMENSIONS AND SITE CONDITIONS TO BE VERIFIED BY FIELD SURVEY AND APPROVED BY BURLINGTON PRIOR TO INSTALLATION.





Scale: 1/4" = 12"

SPEC

Proposed Signage = N/A

Relevant Signage Code
N/A

Sign Type
LED Channel Letters
Front-Lit

Mounting
Flush Mounted

Color Palette

- Face: White Acrylic
- Letters Vinyl: Trans 3M 3630-2120
- Trim Cap & Returns: Black

Project No. 21635
 Project Burlington Signage Package
 Location 5227 N. Broadway Street
 Chicago, IL 60640
 Broadway Plaza
 Orig. Draft 11.16.2022
 Project Mgr. N/A
 Designer IDV
 Rev. Art Steph Chan
 Rev. Date 07.17.2023
 Page Rev. 011
 Rev. Details Revised logo

This sign design is exclusive property of Identiti Resources, LTD., and is the result of the original and creative work of it's employees. This drawing is submitted to the customer for the sole purpose of purchase of the design or signage manufactured to this design, by Identiti Resources, LTD. Distribution to or use of this sign design by anyone outside of the customer's organization, without expressed, written authorization by Identiti Resources, LTD. is prohibited.



ALL LETTERS TO HAVE 10' WHIPS

“B” LOGO SPECIFICATIONS

- ① 2" TRIM CAP: (WITH JEWELITE WASHER HEAD PHILLIPS SCREWS) PAINTED BLACK

LETTER SPECIFICATIONS

- ① 1" TRIM CAP: (WITH JEWELITE WASHER HEAD PHILLIPS SCREWS) PAINTED BLACK

IDENTICAL SPECIFICATIONS

- ② 3/16" SEAMLESS WHITE ACRYLIC FACE WITH APPLIED TRANSLUCENT VINYL TO MATCH PMS 207C
- ③ 0.063 ALUMINUM RETURNS (5" DEPTH) PAINTED BLACK MATTE FINISH
- ④ LED UNITS: SLOAN PRISM RED
- ⑤ 0.063 ALUMINUM BACK: PRECOAT WHITE FINISH
- ⑥ MOUNTING HARDWARE: STEEL FLANGE KNURLED RIVET NUT 1/4-20 WITH NUTS, WASHERS, AND 12" BY 1/4" THREADED ROD, MINIMUM 2 PER LETTER
- ⑦ WEEP HOLES
- ⑧ CONDUIT: CONNECTION THROUGH WALL TO BE WATERTIGHT SECONDARY ELECTRICAL RUN (WHEN NEEDED)
- ⑨ UL LISTED HOUSING: SECONDARY WIRING SPLICE POINT (WHEN NEEDED)
- ⑩ UL HOUSING W/ PWR SUPPLY (QTY VARIES) DISCONNECT SWITCH FOR DEDICATED PRIMARY POWER CIRCUIT
- ⑪ PRIMARY POWER CIRCUIT (PROVIDED/PERMITTED BY OTHERS) TO BE PLACED WITHIN 5 FEET OF CENTER OF SIGN

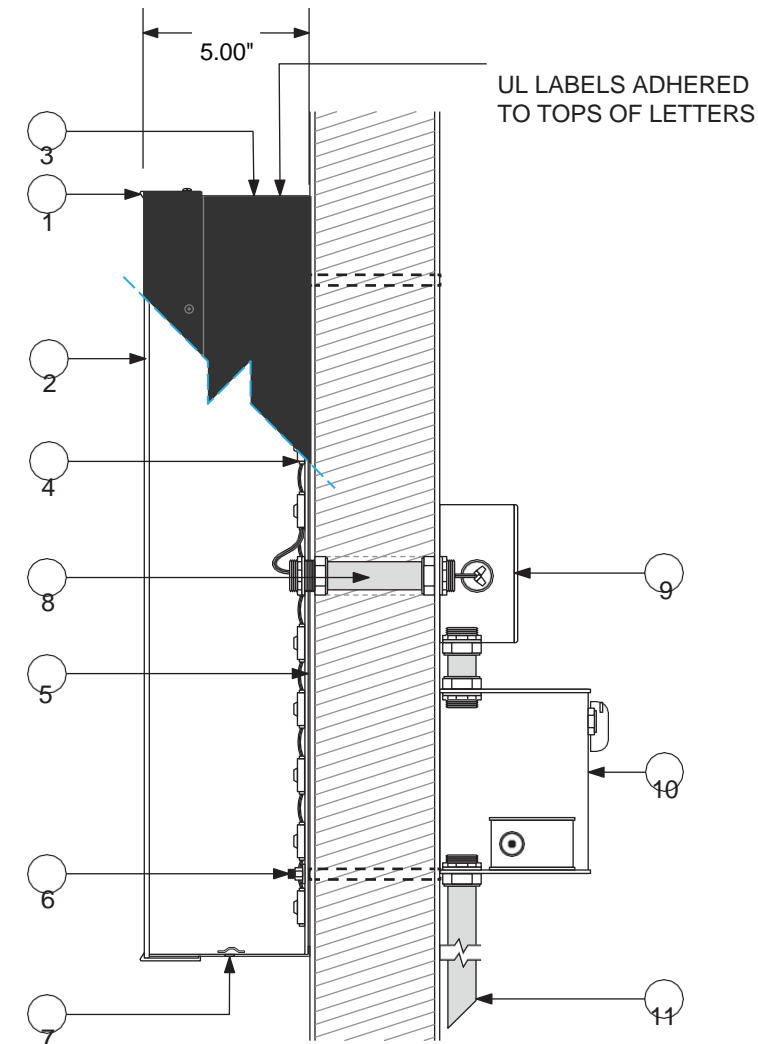

SPEC-Tagline

Proposed Signage = N/A

Relevant Signage Code
N/A

Sign Type
LED Channel Letters
Front-Lit

Mounting
Flush Mounted

Color Palette

- Face: White Acrylic
- Trim Cap & Returns: Black
- Tagline Vinyl: 3M 3630-222 Day/Night Black

Project No. 21635
Project Burlington Signage Package
Location 5227 N. Broadway Street
 Chicago, IL 60640
 Broadway Plaza
Orig. Draft 11.16.2022
Project Mgr. N/A
Designer IDV
Rev. Art Steph Chan
Rev. Date 07.17.2023
Page Rev. 011
Rev. Details Revised logo

This sign design is exclusive property of Identiti Resources, LTD., and is the result of the original and creative work of it's employees. This drawing is submitted to the customer for the sole purpose of purchase of the design or signage manufactured to this design, by Identiti Resources, LTD. Distribution to or use of this sign design by anyone outside of the customer's organization, without expressed, written authorization by Identiti Resources, LTD. is prohibited.

DEALS. BRANDS.

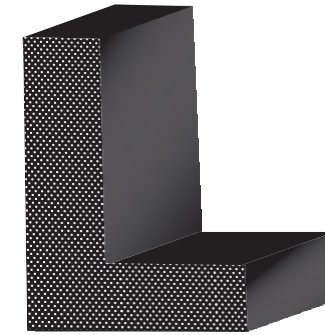

LETTER SPECIFICATIONS

- ① 3/16" ACRYLIC FACE WITH 3M 3630-222 BLACK DAY/NIGHT VINYL, FIRST SURFACE & 3M 30% DIFFUSER APPLIED VINYL, SECOND SURFACE
- ② 1" TRIM CAP: (WITH JEWELITE WASHER HEAD PHILLIPS SCREWS) PAINTED BLACK
- ③ 0.063 ALUMINUM RETURNS (5" DEPTH) PAINTED WHITE SATIN FINISH
- ④ LED UNITS: SLOAN PRISM WHITE
- ⑤ 0.063 ALUMINUM BACK: PRECOAT WHITE FINISH
- ⑥ MOUNTING HARDWARE: STEEL FLANGE KNURLED RIVET NUT 1/4-20 WITH NUTS, WASHERS, AND 12" BY 1/4" THREADED ROD, MINIMUM 2 PER LETTER
- ⑦ WEEP HOLES
- ⑧ CONDUIT: CONNECTION THROUGH WALL TO BE WATERTIGHT SECONDARY ELECTRICAL RUN (WHEN NEEDED)
- ⑨ UL LISTED HOUSING: SECONDARY WIRING SPLICE POINT (WHEN NEEDED)
- ⑩ UL HOUSING W/ PWR SUPPLY (QTY VARIES) DISCONNECT SWITCH FOR DEDICATED PRIMARY POWER CIRCUIT
- ⑪ PRIMARY POWER CIRCUIT (PROVIDED/PERMITTED BY OTHERS) TO BE PLACED WITHIN 5 FEET OF CENTER OF SIGN

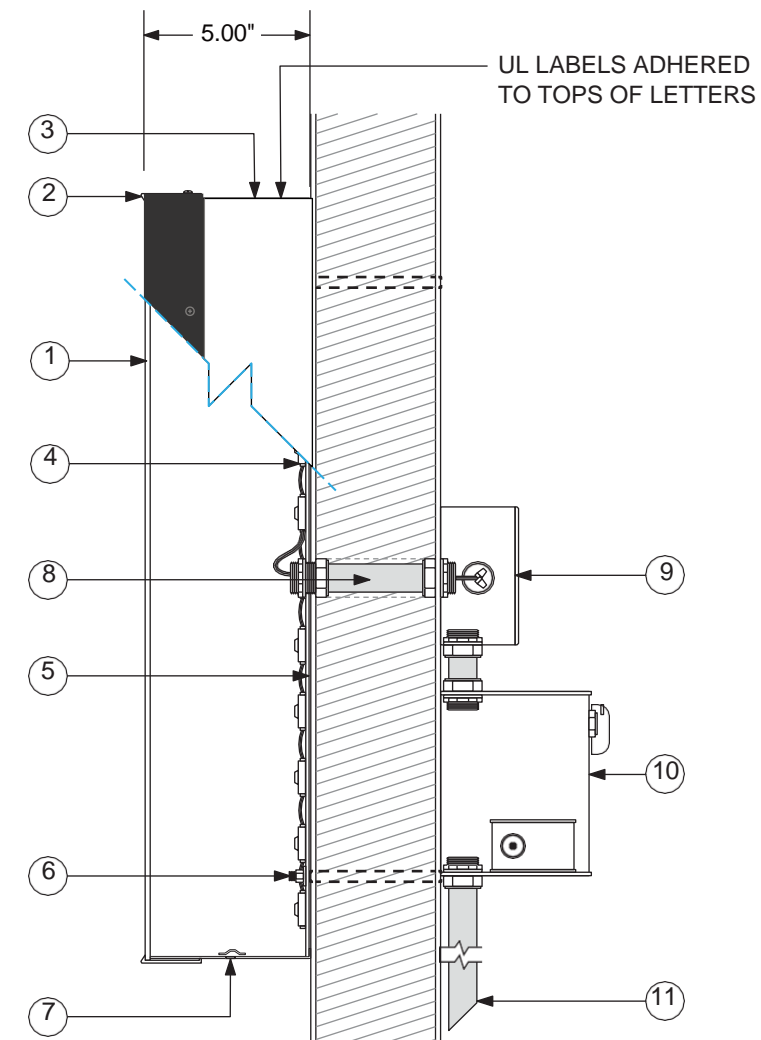

LEGEND	
Front Elevation	S1
Side Elevation	S2
Pylon Sign	P1

Site Plan - Overview

Project No. 21635
Project Burlington Signage Package
Location 5227 N. Broadway Street
 Chicago, IL 60640
 Broadway Plaza
Orig. Draft 11.16.2022
Project Mgr. N/A
Designer IDV
Rev. Art MM
Rev. Date 02.07.23
Page Rev. 005
Rev. Details Added S2

This sign design is exclusive property of Identiti Resources, LTD., and is the result of the original and creative work of its employees. This drawing is submitted to the customer for the sole purpose of purchase of the design or signage manufactured to this design, by Identiti Resources, LTD. Distribution to or use of this sign design by anyone outside of the customer's organization, without expressed, written authorization by Identiti Resources, LTD. is prohibited.

IDENTITI
 425 N Martingale Rd
 18th Floor
 Schaumburg, IL 60173
 O ce 847.301.0510
 identiti.net

